

FOUNDATION AND GROUND FLOOR SLAB LAYOUT
SCALE 1:100

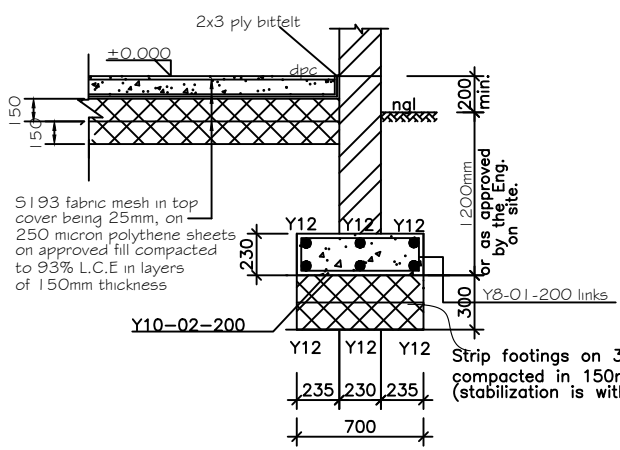

SECTION A-A
SCALE 1:25

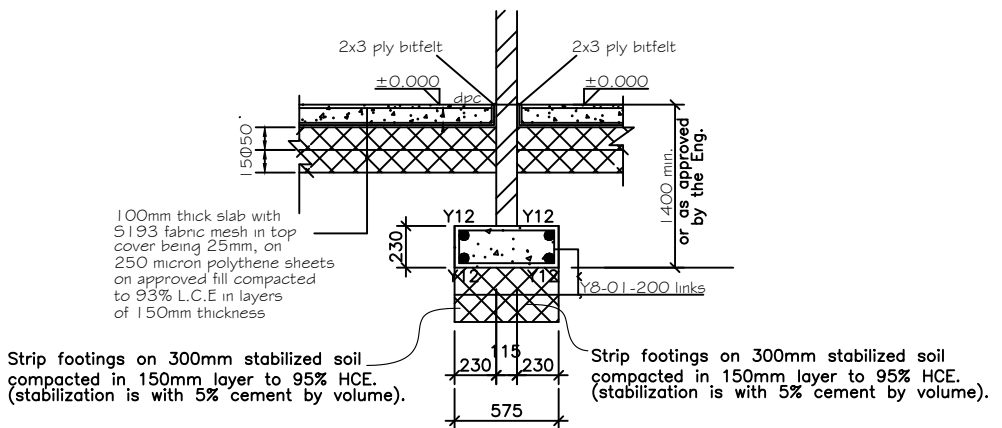

SECTION B-B
SCALE 1:25

BENDING SCHEDULE 1							
MEMBER & NO.	BAR MARK	TYPE & SIZE	No. OF MBRS	No. IN EACH	TOTAL No.	LENGTH (mm)	SHAPE
SF 1: (700X230) SF2,3,10,11,11a, 12,13,14,28,31, &32 12Nos	01	Y8	12	25	300	1550	190 Links 800
	02	Y12	12	6	72	4775	STR
SF 4: (575X230) SF5,7,29 SIMILAR 4Nos	01a	Y8	4	3	12	1375	190 Links 475
	03	Y12	4	4	16	500	STR
SF 8: (575X230) SF6,9,30 SIMILAR 4Nos	01a	Y8	4	15	45	1375	190 Links 475
	04	Y12	4	4	12	2775	STR
SF 15: (700X230) SF19,23,27,36 6Nos	01	Y8	6	49	294	1550	190 Links 800
	05	Y12	6	6	36	9625	STR
SF 16: (575X230) SF22,24 SIMILAR 3Nos	01	Y8	3	7	21	1375	190 Links 575
	06	Y12	3	4	12	900	STR
SF 17: (575X230) SF20,25,33SIMILAR 4Nos	01	Y8	4	7	28	1550	190 Links 800
	07	Y12	4	4	16	1150	STR
SF 18: (575X230) SF21,26,35SIMILAR 4Nos	01	Y8	4	4	16	1375	190 Links 575
	08	Y12	4	2	8	600	STR

- Notes**
1. Read this drawing in conjunction with other architectural and engineering drawings.
 2. Do not scale from this drawing, use the written or calculated dimensions.
 3. Concrete grade to be 25MPa.
 4. Cover to reinforcement: Ground slab - 25mm to mesh
 5. Use precast r.c. lintels for all inside openings.
 6. Foundation depth to be minimum 1400mm from natural ground level, actual to be determined by the Engineer on site.
 7. All excavations and reinforcement to be inspected and approved by the Engineer on site.
 8. Provide backforce after every third course from foundation to ground floor. Elsewhere provide after every fourth course.

AMENDMENT		Description :
Ltr	date	

Ministry of Local Gvt, Public Works
and National Housing
P.O.Box 7706 , Causeway
Zimbabwe

ENGINEER L. CHIKWENHERE	Branch Head T.N. TSAHA	Ministry FINANCE	Centre MUTARE
Designed L. CHIKWENHERE	Scale AS SHOWN	Title ZIMRA STAFF ACCOMMODATION	
Drawn L. CHIKWENHERE	Date MARCH 2022	Description FOUNDATION AND GROUND FLOOR SLAB LAYOUT, FOUNDATION R.C DETAILS, BENDING SCHEDULE AND SECTIONS	
Checked C. KANYASA	File Ref	GP No	Project No /S/02
TELEPHONE 728201-9			